



CB Can Blowers

From *Recycling Equipment Manufacturing, Inc.*



REM's® model CB can blower can be used to transport both loose un-flattened and flattened cans into a trailer or other container. Save money on one of your largest expenses, labor, by putting this unit to work for you. When fed by REM's® model PRC Pre Crusher, MS Magnetic Separator, or MCB Master Can Buyer; this unit makes can transport a breeze!

PROVEN DESIGN

REM's® second generation field-proven blower design is easy to service, built for long life and low maintenance. This tough, rugged unit is mounted on casters for ease of movement – just push it in place, lock the casters, adjust the blow-tube, and watch your bottom line grow.

PLASTIC BOTTLE BLOWER

Now available in a PET bottle blower configuration, featuring a larger diameter blower housing and blow-tube to move your PET and HDPE with ease. To put REM's® model CB series Blowers to work for you call **1-800-745-4736**.



CB Can Blower

A Leader in Recycling Equipment Since 1978

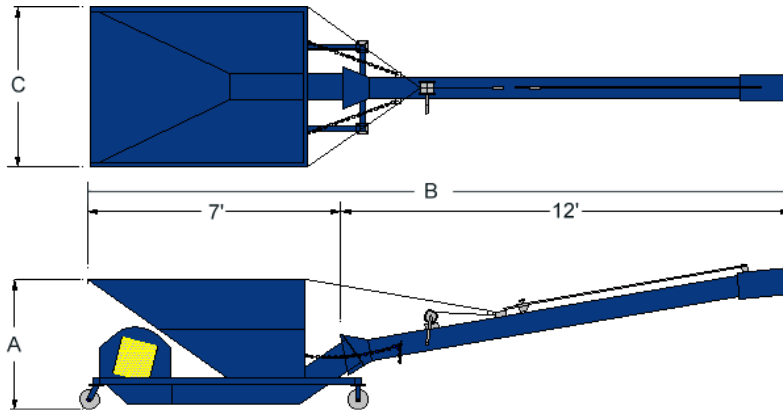

Features:

- High-performance cast aluminum reverse incline blower keeps cans from jamming
- Large 1 cubic yard hopper
- 10" diameter x 12' adjustable blow tube with support cable and brake winch
- Mounted on 4" steel casters for mobility
- Processes up to 3,500 lbs. of cans per hour
- Blow tube safety restraints

Specifications:

- All steel unitized construction
- 4" industrial casters with built-in wheel-locks
- 7.5 HP TEFC blower motor
- 13" diameter cast aluminum fan with 6" blades

Dimensions:	CB
Height (A)	40"
Length (B)	20'
Width (C)	48"
Weight approx. (lbs.)	685

Electrical safety features:

- 240/480 volt, three phase
- Electrical components are UL listed
- NEMA-3R (outdoor) enclosure
- Manual start switches with thermal overload protection

Options:

- 240 volt, single phase
- 208, 380, 415, 480, or 575 volt, three phase wiring
- Power cord
- Custom hopper and blow tubes
- 60" wide, 1-1/3 cu. yd. hopper
- PET and HDPE bottle blower
- If you don't see it, ask us!

LIMITED ONE YEAR WARRANTY

- *All dimensions are nominal +/- 1"
- *Specifications subject to change without notice, without incurring responsibility to previous units sold

Recycling Equipment Manufacturing, Inc.

PO Box 310 1-800-745-4736
 Priest River, Idaho www.remfg.com Office: (208) 448-4736
 USA 83856 E-mail: sales@remfg.com Fax: (208) 448-1786

© 2000 REM, INC.

Sales and Service