



## MV Perf Series Perforator

From *Recycling Equipment Manufacturing, Inc.*

**“THE EXTREME BEER, SOFT DRINK, AND JUICE DRINKER”**



CRUSH THE CANS...  
PERFORATE THE PET...  
FRESH WATER RINSE...  
LIQUID FLOWS INTO DRAIN...

Process full beverage “line rejects” or “out dated product” and recover aluminum cans and PET Containers for recycling on an extreme scale with REM® Series MV Perf Crushing System. Our Model MV-PERF processes both PET containers as well as aluminum cans. Each model comes complete with an in-feed conveyor, totally enclosed crushing mechanism and an out-feed screw conveyor with fresh water rinse. Our Model MV- PERF was designed after our Model HV PERF that has proven its capabilities for many years in the field.

### **PROVEN DESIGN**

Product is loaded on the in-feed conveyor hopper and is conveyed up into MV PERF mechanism where the containers are perforated and crushed with the beverage fluid discharging into the (optional) capture tank. The beverage containers are then discharged onto the out-feed screw conveyor where they run under a fresh water rinse aiding in the removal of residual beverage fluids. The containers are discharged into a waiting container. Incorporate a REM® Model PET Bottle Blower or a baler to make this a complete full beverage container recycling system.

To put our model MV PERF to work for you, call **1-800-745-4736**.



# MV Perf Series Crushers

A Leader in Recycling Equipment Since 1978

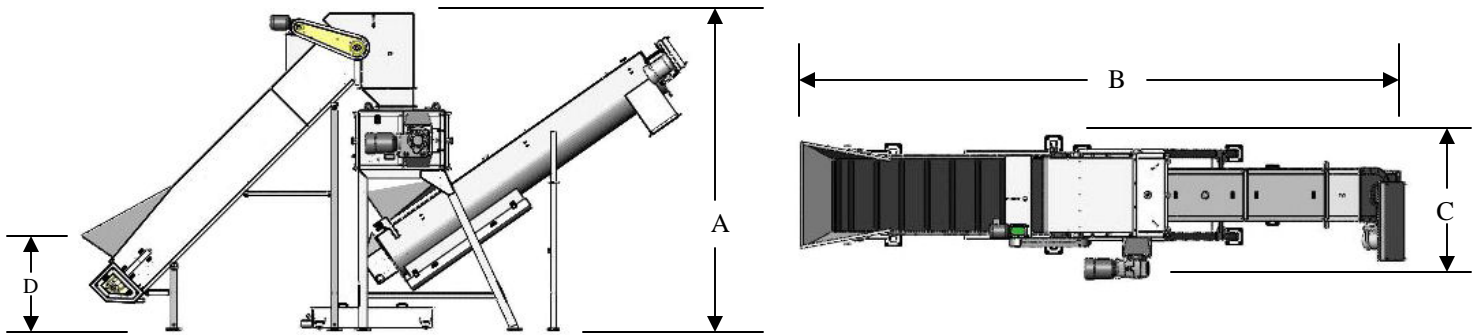

## Features:

- Third generation field-proven design for extremely high volume, low maintenance, and easy service
- Enclosed tail pulley cover with external take-ups for correct belt tracking and tension
- Low in-feed hopper for easy loading/visual inspection
- Enclosed belt and chain guards for user protection
- Fresh water rinse on out feed conveyor
- Processes up to 1100 cases of aluminum cans or up to 8000 PET bottles per hour.

## Specifications:

- Structural steel frame construction
- PVC-150 conveyor belting with vulcanized cleats and Flexco 125 Megalloy Lacing
- 8" diameter head pulley, and 6" diameter crowned tail pulley
- Enclosed sides and bottom of belt return pan
- 1 HP TEFC conveyor motor
- 7.5 HP TEFC crusher motor
- Crusher Motor brake for added safety

## Electrical safety features:

- 240/480 volt, three phase
- Electrical components are UL listed
- NEMA-4 (hose proof) enclosure
- Sequential manual start motor controls
- Main safety fused disconnect
- Individual motor overload/short circuit protection
- Safety interlock on crusher access door

Dimensions:	MV Perf
Height (A)	13' 3.3"
Length (B)	23' 8.5"
Width (C)	6' 0"
Loading Height (D)	48"
Weight approx. (lbs.)	8175
<b>Hopper:</b>	
Capacity	1 cu. Yard
<b>Conveyor:</b>	
Discharge Height	9' 1"
Belt width-Infeed	36"

## Options:

- 240 volt, single phase
- Stainless steel upgrade
- 208, 380, 415, 480, or 575 volt, three phase
- Power cord
- Custom conveyors, hoppers, discharge heights
- Pump with a 120 gallon fluid capture tank
- Wash-down duty bearings & motors
- Automatic Lubrication System
- If you don't see it, ask us!

## LIMITED ONE YEAR WARRANTY

\*All dimensions are nominal +/- 1"

\*Specifications subject to change without notice, without incurring responsibility to previous units sold

Recycling Equipment Manufacturing, Inc.

PO Box 310 1-800-745-4736  
 Priest River, Idaho www.remfg.com Office: (208) 448-4736  
 USA 83856 E-mail: sales@remfg.com Fax: (208) 448-1786

Sales and Service
-------------------