



CBS Series Magnetic Separator

From *Recycling Equipment Manufacturing, Inc.*

CROSSBELT MAGNETIC SEPARATOR.



* Shown with optional adjustable support legs, pulley covers.

REM's® model CBS Crossbelt Magnetic Separator is a versatile plate magnet that is supplied with lifting eyes for suspension over REM's® model SC Sorting Conveyor, TRC Transfer Conveyor, or other conveyor units.

INCREASE YOUR PRODUCTIVITY

The unique design of our plate magnet in the CBS enables it to have a pulling range of 15" to easily handle the larger cans found in today's recycling markets. Our model CBS will help you achieve a cleaner sort by eliminating picker error and fatigue, and increase your profits. Available in five models, REM's® CBS crossbelt will efficiently handle up to a 60" wide conveyor system. To put our model CBS Crossbelt magnetic separator to work for you, call **1-800-745-4736**

**We recommend a stainless steel section in the conveyor REM® Model SCSS under the crossbelt magnetic separator for superior separating results.



CBS Series Magnetic Separator

A Leader in Recycling Equipment Since 1978

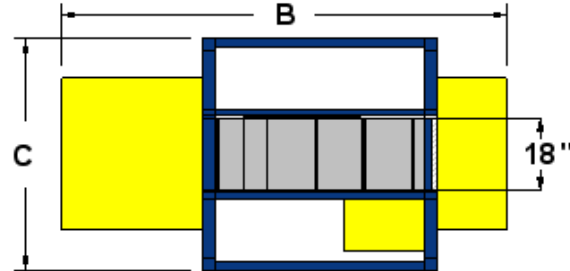
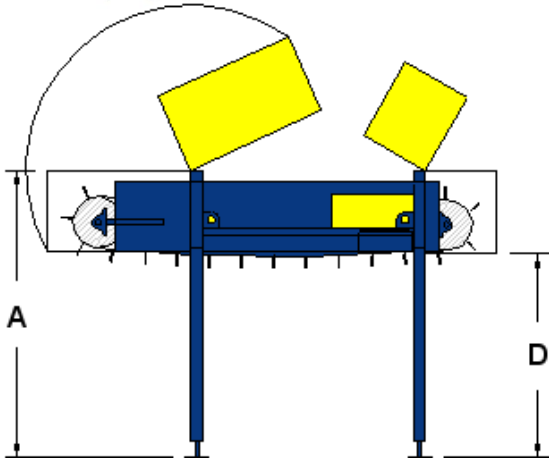

Features:

- Unique plate magnet design
- Stripper magnet for controlled discharge
- Completely enclosed drive package
- 1/2 to 2 HP motor, depending on model

Specifications:

- All-steel unitized construction
- Crowned head and tail pulley
- 18" wide 3-ply 330 rubber belting with 3" vulcanized cleats and Flexco 187 Stainless Lacing (CBS 6 and 8)
- 30" wide 3-ply 330 rubber belting with 3" vulcanized cleats and Flexco 187 Stainless Lacing (CBS 9, 10, and 12)

Dimensions:	CBS-8	CBS-10
Height (A)	67" to 76"	
Length (B)	9' 3"	11' 6"
Width (C)	58"	58"
Discharge Height (D)	48" to 60"	
Weight approx. (lbs)	1,800	3,000

Electrical :

- 240/480 volt, three phase
- Electrical components are UL listed

Options:

- 240 volt, single phase
- 208, 380, 415, 480, or 575 volt, three phase
- Frame with legs
- Swing away doors for easy maintenance
- If you don't see it, ask us!

LIMITED ONE YEAR WARRANTY

*All dimensions are nominal +/- 1"

*Specifications subject to change without notice, without incurring responsibility to previous units sold.

Recycling Equipment Manufacturing, Inc.

PO Box 310
 Priest River, Idaho 83856
 USA

www.remfg.com
 E-mail: sales@remfg.com

1-800-745-4736
 Office: (208) 448-4736
 Fax: (208) 448-1786

© 2000 REM, INC.

Sales and Service